

ONCE FOR ALL

INSTRUCTION MANUAL RECIPE GUIDE

MANDOLINE SLICER

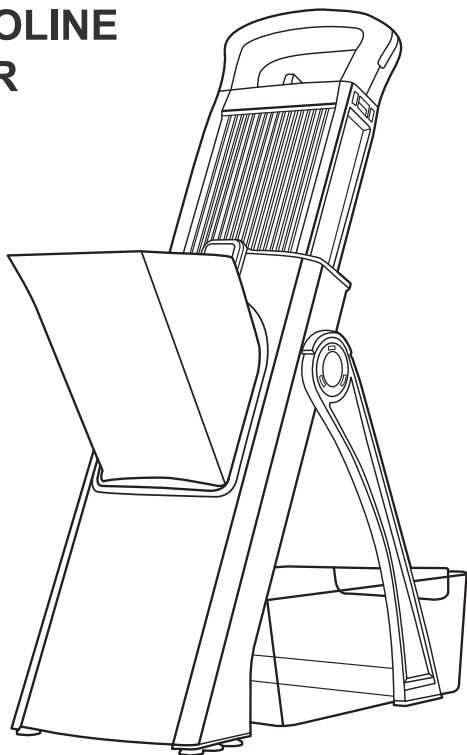

ONCE FOR ALL

Thanks for purchasing the **ONCE FOR ALL** Rapid Mandoline Slicer. If you have any questions about the services or products.

- Please feel free to contact us via email: sales10@jinshungroup.com
- Be sure to read this manual carefully before use.
- Please keep this manual after reading it.



WARNING: NEVER insert your fingers in or near the Blade to dislodge food.

Manual

Safety & Warning	2
Easy To Use	3
Product List	3
Assembly	4-6
Guide to Cuts & Slices	7
Questions & Answer	8
Slicing	9-10
Matchstick	11-12
Julienne	13-14
Dice	15-16
Chop	17-18
Clean	19
Store	20
Recipes	21-22

Safety & Warning

This Mandoline uses sharp blades. Exercise extreme caution when using and cleaning the Mandoline to avoid personal injury, including:

- Before using the product, please assemble it correctly and follow the instructions.
- Make sure the Mandoline Slicer is cleaned thoroughly before using.
- Do not use the Mandoline Slicer for other than its intended use. For household use only.
- Close supervision is necessary when any Mandoline Slicer is used by or near children.
- Never touch the blades while in use. Never touch moving parts.
- Never add ingredients while the Mandoline Slicer is operating.
- Never use hot ingredients. When cutting short or small ingredients, be sure to use the Food Pusher.
- Do not cut ingredients too hard or too soft and cut unapplicable food.
- Do not place the Mandoline Slicer on or near a hot gas burner, hot electric burner, or in a heated oven.
- This Mandoline Slicer is not intended for use by persons (including children) with reduced physical, sensory, or mental capabilities, or lack of experience and knowledge unless they are provided with supervision and instruction concerning use of the Mandoline Slicer by a person responsible for their safety.
- Shall not accept liability for damages caused by improper use of the Mandoline Slicer.

Easy To Use

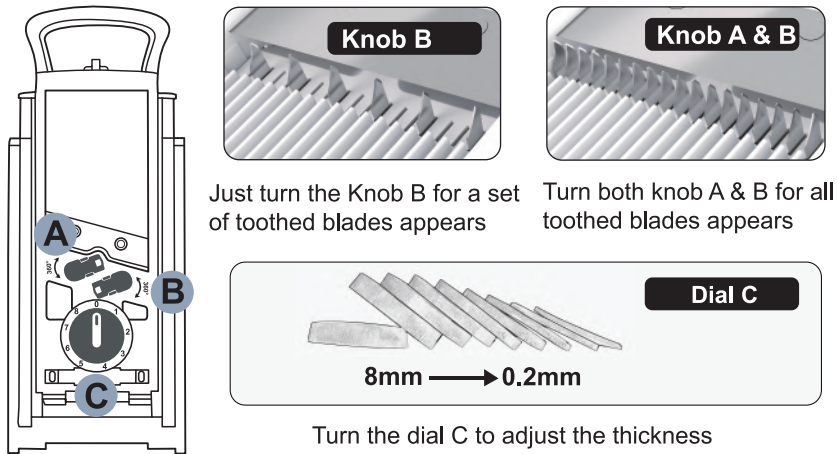

Assembly

- 1 Fully unfold the slicer and put it on a flat stable surface.

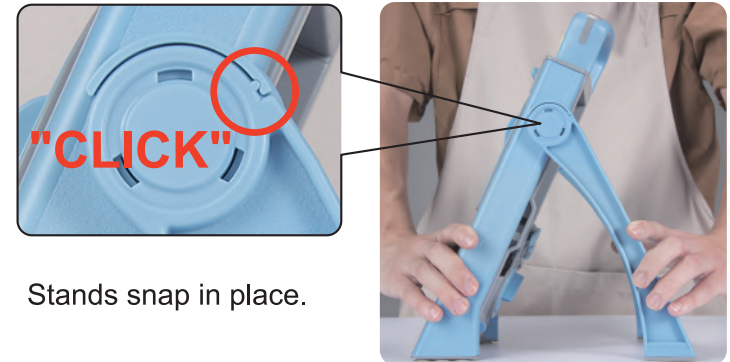

Product List

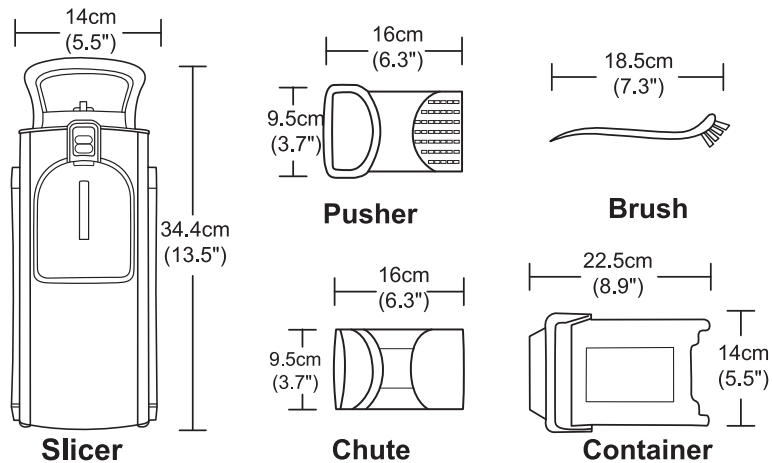

- 2 Pressing upward on the tab to lift the Chute Release.



Assembly

- 3 Pressing upward on the tab to lift the Chute Release again.



With the Chute Release lifted, insert the Food Chute.

- 4 Put the Container beneath the mandoline, and be sure the lip fits securely on the lower bar of the main stand.



Assembly

- 5 Twist the Handle clockwise to unlock the Handle before using.



Be careful as the Handle is spring loaded and will release quickly!

- 6 Unsnap the Knob and rotate it a full 360° to adjust the blades.

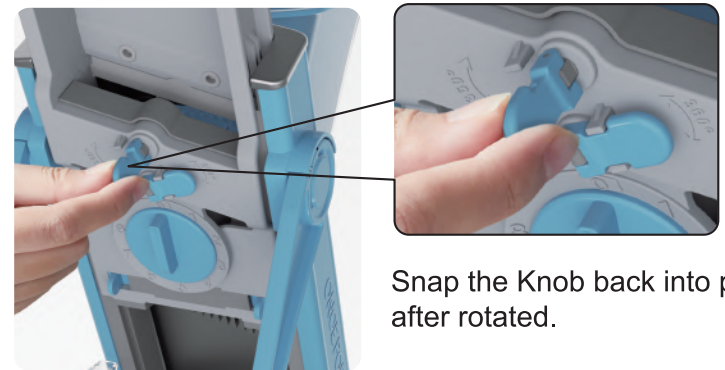

Snap the Knob back into place after rotated.

Guide to Cuts & Slices

Mode 1: Slice

Only turn the dial C

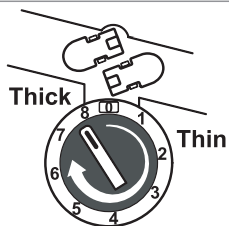

Mode 2: Strip

Turn the knob B and the dial C

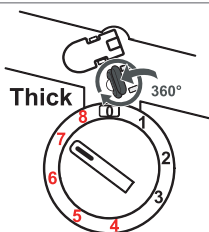

Mode 3: Julienne

Turn the knob both A & B and the dial C

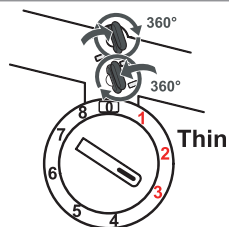

Mode 1: Slice

+

Mode 2: Dice

Slice first, then dice

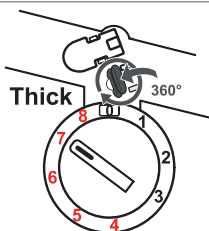

For more detailed operation steps, please see pages 9-18.

Questions & Answer

Q: Why can't I cut out the shape I want with this slicer?

A: Please refer to the 5 modes shown on pages 9-18 of the manual. Please adjust the knobs and dial to match the pictures, and check whether the blade is the same as shown in the pictures.

Q: Why is it difficult to cut the ingredients when using the pusher?

A: If it is difficult to cut ingredients, please try to reduce your power of pushing them to ensure the slicer can cut smoothly and quickly.

Q: Ingredients are too large to put into the food chute?

A: You need to cut the ingredients into suitable sizes first.

Q: Recommended uses for our mandoline slicer ?

A: Potato, onion, tomato, cucumber, carrot, pepper, zucchini, celery, cabbage, lemon, banana, apple... most of the vegetables, fruits, and spices you want to process can be easily chopped, sliced, and diced. But please do not try to deal with ingredients that are too hard, with bones, too soft or too juicy.

Q: How to clean and store this slicer?

A: You can clean this slicer by hand wash with the included detail brush, but please don't touch the blades with your finger. Or you can use the dishwasher (top rack recommended). After cleaning the slicer, please dry it and fold up for storage.

Q: Some foods may dye the slicer after being cut?

A: Some ingredients with a large amount of plant pigments, such as carrots, spinach, purple cabbage, etc., the juice produced after cutting may indeed dye the slicer. Therefore, please clean the slicer as soon as possible after handling these ingredients to avoid this situation. If your mandoline already has become dyed, try cleaning it with cooking oil.

Slicing



1 Adjust the thickness

- Please assemble the product first according to the instructions on pages 4-6.
- Turn the Dial C (Thickness Adjuster) to your preferred slice size.
- The Dial C (Thickness Adjuster) ranges from 0-8 millimeters.
- Higher numbers correspond to thicker slices.
- No need to adjust Knob A & B.

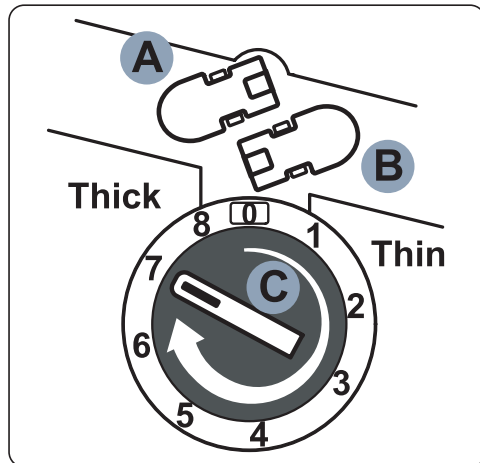

Scan the QR code to view the video →



2 Place your ingredients into the Food Chute

Remove the Pusher before you put your ingredients in.



Use the Pusher to guide the ingredient against the Blade

3 Push down the Handle to slice & release



Matchstick



1 Setting

- Please assemble the product first according to the instructions on pages 4-6.
- Turn the Dial C (Thickness Adjuster) to number 4-8.
- Unsnap Knob B and rotate it a full 360°.
- Snap the Knob back into place after rotated.

You should see a set of toothed blades appears at the top of the Blade Runway.

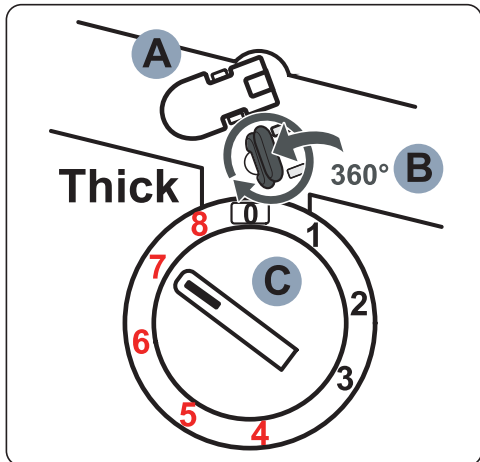
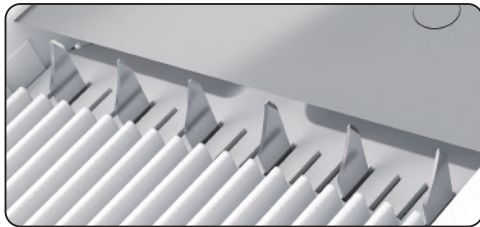

Scan the QR code to view the video →



2 Place your ingredients into the Food Chute

Remove the Pusher before you put your ingredients in.



Use the Pusher to guide the ingredient against the Blade

3 Push down the Handle to slice & release



Julienne



Scan the QR code to view the video →



1 Setting

- Please assemble the product first according to the instructions on pages 4-6.
- Turn the Dial C (Thickness Adjuster) to number 1-3.
- Unsnap both Knob A & B and rotate them a full 360°.
- Snap the Knobs back into place after rotated.

You should see all of toothed blades appears at the top of the Blade Runway.

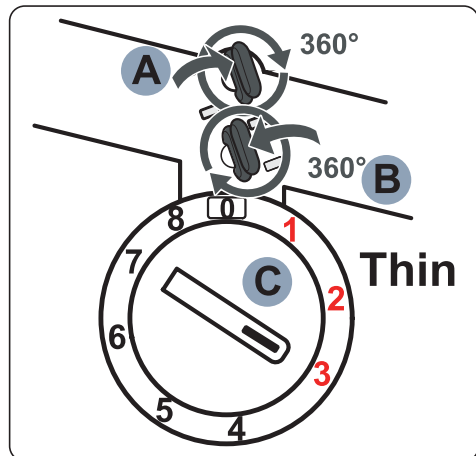
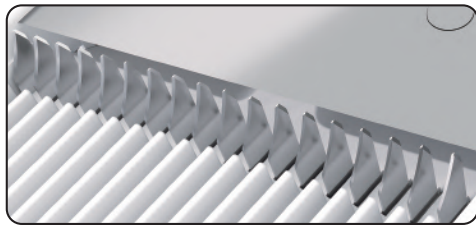

2 Place your ingredients into the Food Chute

Remove the Pusher before you put your ingredients in.



Use the Pusher to guide the ingredient against the Blade

3 Push down the Handle to slice & release



Dice



Scan the QR code to view the video →



1 Setting

- Please assemble the product first according to the instructions on pages 4-6.
- Turn the Dial C (Thickness Adjuster) to number 4-8.
- Slice your ingredients first, please refer to pages 9-10.
- Put the sliced ingredients back into the Food Chute.
- Unsnap Knob B and rotate it a full 360°.
- Snap the Knob back into place after rotated.

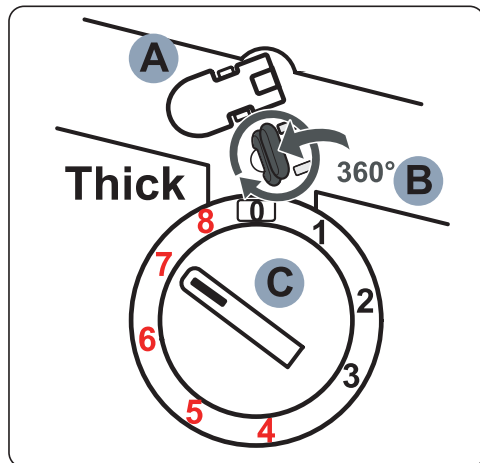
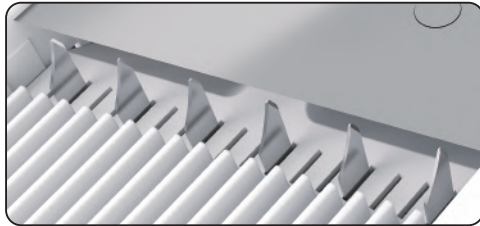

2 Place your sliced ingredients into the Food Chute

Remove the Pusher before you put your ingredients in.



Use the Pusher to guide the ingredient against the Blade

3 Push down the Handle to slice & release



Chop



Scan the QR code to view the video →



1 Setting

- Please assemble the product first according to the instructions on pages 4-6.
- Turn the Dial C (Thickness Adjuster) to number 1-2.
- Slice your ingredients first, please refer to pages 9-10.
- Put the sliced ingredients back into the Food Chute.
- Unsnap both Knob A & B and rotate them a full 360°.
- Snap the Knobs back into place after rotated.

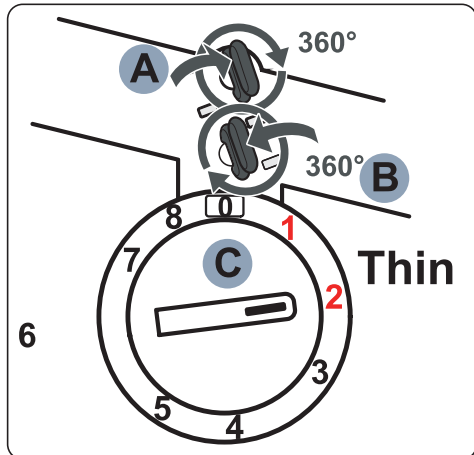
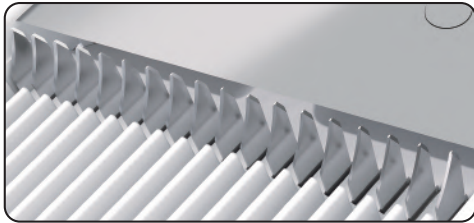

2 Place your sliced ingredients into the Food Chute

Remove the Pusher before you put your ingredients in.



Use the Pusher to guide the ingredient against the Blade

3 Push down the Handle to slice & release



Clean

Retract the blades and turn the Dial C to 8 for cleaning, after that turn to 0 for storage.

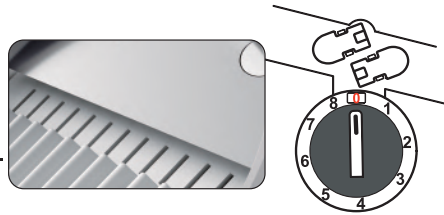

One-click Disassembly

Slide both sliders inward to unlock the body and pull it out simultaneously.



Hand Wash

Before cleaning, please use the other end of the brush (the tip end) to remove food residue from the mandoline.



Dishwasher Safe

It is dishwasher safe, but please take it out after cleaning and dry it with a clean cloth. Do not use the dishwasher for drying.



Store

- Fold the mandoline for storage after cleaning



Folded for storage



Easy To Store

- Please store in a cool and dry place and keep away from children

Global Patents' No

USA: D887 794 S

USA: 10 974 411 B2

EU: 005621836-0001

EPO: 3608070

 **WARNING:** NEVER insert your fingers in or near the Blade to dislodge food.

Creamy Cucumber Salad

PREP TIME: 15 minutes SERVES: 4

This gorgeous salad will come together in minutes by using our rapid mandoline slicer! It's pairs perfectly with any spicy dish. Refreshing, crisp and flavorful!



Ingredients:

- 2 large English cucumbers, thinly sliced, skin on
- 1/2 bunch cilantro
- 1 jalapeno, seeded and finely diced
- 1/4 of a red onion, very thinly sliced
- 3 tablespoons fresh lime juice
- 1/2 teaspoon chili flakes
- 1/2 teaspoon ground coriander
- Salt to taste
- Creamy Cilantro Lime Dressing

Directions:

- ① Use the mandoline slicer to handle ingredients.
- ② Turn the dial C to 3 to make thin slice and 1 to make very thin slice.
- ③ Slice the ingredients first if you want to dice.
- ④ Place all ingredients in a bowl, and gently toss.
- ⑤ Taste and adjust the salt.

Tips:

Cutting the cucumbers thicker (1/4 inch) will keep them crisper longer. This salad is best served fresh!

Cucumber and Tomato Chopped Salad

PREP TIME: 10 minutes

This colorful chopped salad tastes great with anything, but we especially love it served with pasta and fresh avocado! With no cook time, it's the perfect light and refreshing lunch or side dish for any summer meal.



Ingredients:

- 2 cups cherry or grape tomatoes, halved or quartered
- 2 large cucumbers, quartered
- 1 medium red onion, sliced thin
- 1/4 cup feta cheese
- 2/3 cup of Avocado Oil Herb Vinaigrette

Directions:

- ① Use the mandoline slicer to handle ingredients.
- ② Turn the dial C to 3 to make thin red onion slice
- ③ Mix all ingredients together and chill before serving.
- ④ Salt and pepper to taste.

Tips:

Delicious with pasta and avocado!